



## CUBE STORAGE

The Cube series is our storage proposal without a metal body. It represents a step forwards, introducing bilaminated wood as the structural element. The units are designed for delivery by parts and on-site assembly.



### STANDARD FEATURES

- ▶ Mastered lock with hinged key.
- ▶ 95° opening hinges.
- ▶ Levelling from the inside up to 25 mm.

# TECHNICAL SHEET



### OPTIONAL FEATURES

#### TOP AND REAR

- ▶ Without top or with 25-mm thick top or continuous top.
- ▶ 19-mm thick melamine rear. IMPORTANT: requires a top with a depth of unit depth +19 mm, to be ordered separately.

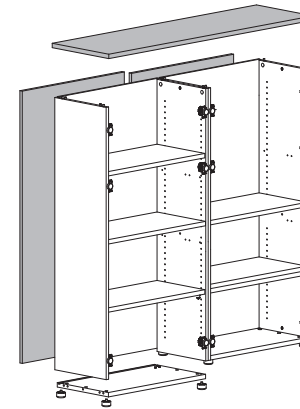

▶ Without rear

▶ With rear

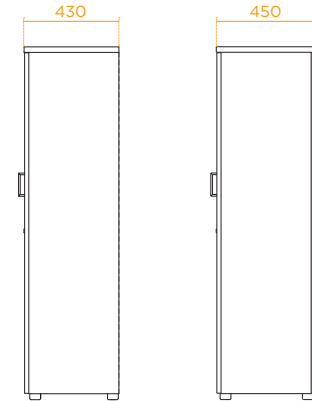

#### SHELVES

- ▶ Wardrobe shelf for hanging clothes or fixed or movable metal shelves which can be used to hang folders, all with a thickness of 25 mm.

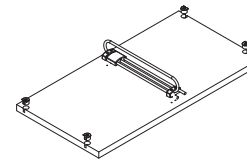

#### PULL-OUT FILING

Maximum height 1000 mm.

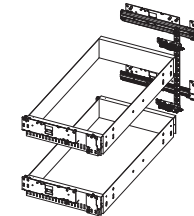

#### PLANTER

- ▶ Assembly in 19-mm thick melamine.
- \* The planter is not suitable for natural plants.

A= 450/700/800/900/  
1000/1400/1600/1800

